

Quality is more than a word

ESPEC

The proposal of safety features for secondary battery



Safe environmental test

This leaflet is to introduce safety features that could be added to our chambers not only based on our experience but also based on the EUCAR Hazard Level.

We describe recommended safety features needed in the event of an abnormality in the secondary battery during tests. To ensure the safety of surrounding workers and installation site, we suggest adding safety features according to the EUCAR (European Council for Automotive R&D) Hazard Level.

Please examine the characteristics of the sample and the test contents under the severe environmental testing carefully before selecting the appropriate option.

The safety features can be adapted individually, according to customer specifications.

Please contact us for more detailed information.

TEST IN TEMPERATURE ENVIRONMENT

EUCAR Hazard Levels

Hazard Level	Description	Classification criteria, effect
0	No effect	No effect. No loss of functionality.
1	Passive protection activated	No defect; no leakage; no venting, fire or flame; no rupture; no explosion; no exothermic reaction or thermal runaway. Cell reversibly damaged. Repair is needed.
2	Defect / Damage	No leakage; no venting, fire or flame; no rupture; no explosion; no exothermic reaction or thermal runaway. Cell irreversibly damaged. Repair is needed.
3	Leakage Δ mass < 50%	No venting, fire or flame; no rupture; no explosion. Weight loss < 50 % of electrolyte weight (electrolyte = solvent + salt).
4	Venting Δ mass \geq 50%	No fire or flame, no rupture; no explosion. Weight loss \geq 50 % of electrolyte weight (electrolyte = solvent + salt).
5	Fire or Flame	No rupture; no explosion (i.e., no flying parts).
6	Rupture	No explosion, but flying parts of the active mass.
7	Explosion	Explosion (i.e. disintegration of the cell)

HAZARD LEVEL AND RECOMMENDED SAFETY DEVICE OPTIONS

Hazard Level 0-2



Status indicator light



Emergency stop switch



Electronic door lock



Lever door lock

Hazard Level 3-4

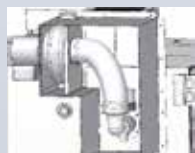

Forced air supply/exhaust damper



Window protection cover



Gas sensor (CO, H₂, HC)



Smoke sensor

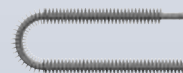

Sheathed fin heaters



External Signal terminal

Hazard Level 5-6

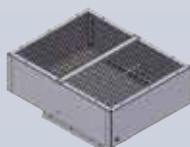

Pressure relief vent 300 x 300 mm



Screw door lock



Additional overheat protector



Port for CO₂ fire extinguisher

Safety device options

DETAIL OF HAZARD LEVEL 0-2



Lever door lock

Secure the chamber door by lever operation. The inner shaft connected to the lever fixes the upper and lower parts of the door. Even if an explosion occurs in the test area, the door rock will prevent from opening the door to protect.

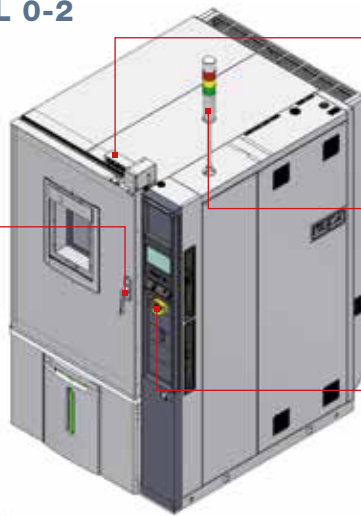

Electronic door lock

After the door of the test area is manually closed, the electromagnetic lock is automatically set and the door is secured.



Status indicator light

The color code shows the chamber status. For example, red is trouble. green is running.



Emergency stop switch

Pressing the emergency stop switch immediately stops all operations of the chamber.

DETAIL OF HAZARD LEVEL 3-4



Window protection cover

Stainless steel plate for viewing window glass scattering protection. Even if an explosion occurs in the test area and the viewing window glass breaks, the stainless steel plate prevents the glass from scattering around. Please order this option together with pressure relief vent.

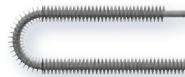
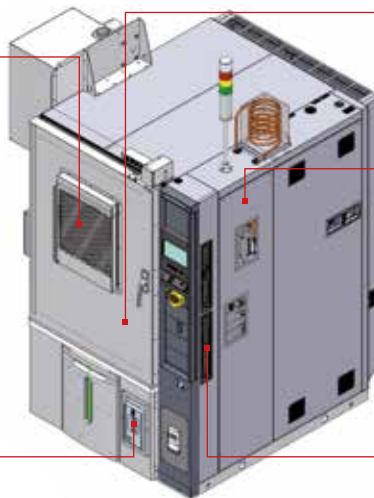

Sheathed fin heater

The nichrome wire of the heater is wrapped in a metal pipe and insulated.



Smoke sensor

Detect smoke in the test area. When smoke is detected, the heater of the chamber, the cooler and air flow stop, and the ventilator is activated to ventilate the test area. The chamber sends an error message. Stop the ventilator after a while and activate the fire extinguisher.*



Gas sensor (CO, H₂, HC=Hydrocarbon)

Detect gas concentration in test area. Gas concentration is detected in two stages. At the first stage, stop the airflow and heater and cooler, activate the ventilator and ventilate the test area. The chamber then sends an error message. Stop the ventilator at the next stage and activate the fire extinguisher. The chamber sends another error message.*



External Signal terminal

Terminal for inputting signals from the charge/discharge tester and test equipment to the chamber side. The chamber can stop in response to a battery abnormality signal or stop signal. Also, it is possible to output an error signal from the chamber. Various interfaces can be built as necessary.



Suction damper

The suction damper is installed on the left side of the chamber. A through hole of Ø50 or Ø100 connects the test area to the outside. The damper operates with signals from various detectors installed separately. Motor valve:100VAC 9w

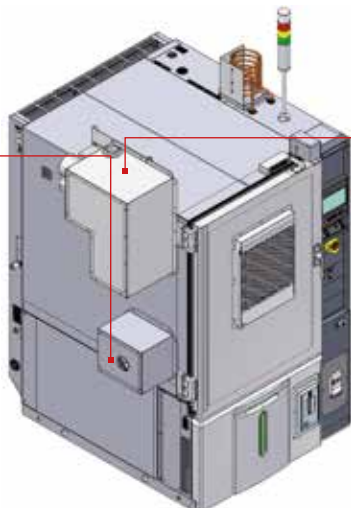

Forced air supply / Exhaust damper

Exhaust fan and ducting in a building are scope of the customers. The exhaust damper and exhaust fan is installed on the left side of the chamber. A through hole of Ø50 or Ø100 connects the test area to the outside. The damper operates with signals from various detectors installed separately. Motor valve:100VAC 9w

Safety device options

DETAIL OF HAZARD LEVEL 5-6



Port for CO₂ fire extinguisher

The fire extinguisher port is installed on the left side of the chamber. A through hole of Ø25 connects the test area to the outside. A silicone rubber plug is included to seal the test area.

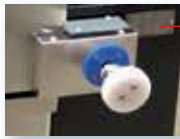

Screw door lock

Secure the chamber door with screw. Even if an explosion occurs in the test area, the door lock will prevent from opening the door to protect.

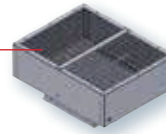
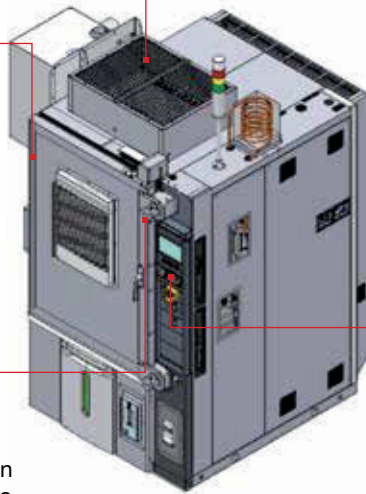

Pressure release vent 300 x 300 mm

The pressure release vent is installed at the top of the chamber. It consists of aluminum foil, glass wool and stainless steel plate. When an explosion occurs in the test area, the aluminum foil installed inside the chamber tears and releases pressure. Replacement aluminum foil is included in orders. Please order this option together with Window protection cover.



Additional overheat protector

Detects air temperature or specimen temperature in test area. You can set the temperature to activate the safety device with the temperature setting unit installed in the chamber. When the measured temperature exceeds the set temperature, the chamber heater, cooler and air flow stop, and the ventilator is activated to ventilate the test area. The chamber sends an error message. After a while, stop the ventilator and start fire extinguisher. *



N₂ gas introduction hole

Suction hole for smoke and gas detection

Please contact us as we can change the operation of safety device as necessary.

VARIOUS PRODUCTS



PL-4

PU-4, PL-4*	
Test area volume:	800 l
Temp. range:	-40°C to +100°C
*Humidity range:	20 %rh to 98 %rh
Change rate Heating:	3.0 K/min
Change rate Cooling:	2.0 K/min
Sound level:	36 - 60 dB
Other models:	120, 225, 408 l



ARS-1100

ARG-1100, ARS-1100*		ARGF-800-15 ARSF-800-15*
Test area volume:	1100 l	784 l
Temp. range:	-75/-45°C to +180°C	-70°C to +180°C
*Humidity range:	10 %rh to 98 %rh	10 %rh to 98 %rh
Change rate Heating:	4.7 - 6.0 K/min	10 - 18 K/min
Change rate Cooling:	4.0 - 4.9 K/min	10 - 18 K/min
Sound level:	57 - 63 dB	65 dB
Other models:	220, 380, 680 l	249, 398 l



SU-662

SU-662	
Test area volume:	64 l
Temp. range:	-60/-40/-20°C to +150°C
Change rate Heating:	3.1/2.9 K/min
Change rate Cooling:	2.1/1.7 K/min
Sound level:	42 - 54 dB
Other model:	22.5 l



T-4

T-4	
Test area volume:	3750 l
Temp. range:	-50° to +150°
Humidity range:	20 % to 95 %rh
Sound level:	approx. 70 dB
Other models:	size flexible

Operation of safety device

GAS SENSOR

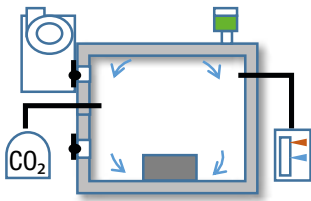

Normal test condition.

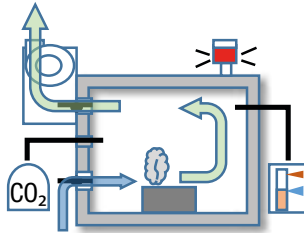

Stage 1 gas detection. Open the damper and exhaust the gas.

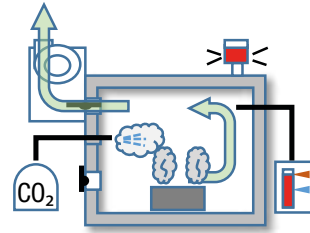

Stage 2 gas detection. Suction damper is close and fire CO₂ extinguisher is injected.

SMOKE SENSOR

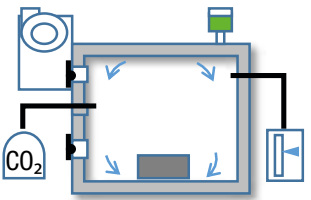

Normal test condition.

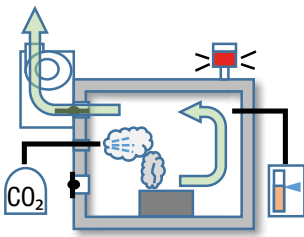

Detect smoke in test area and inject CO₂ fire extinguisher.

TEMPERATURE SENSOR

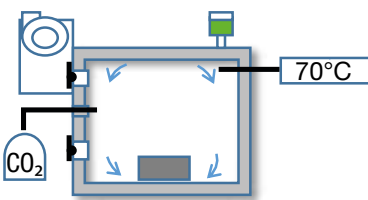

Normal test condition.

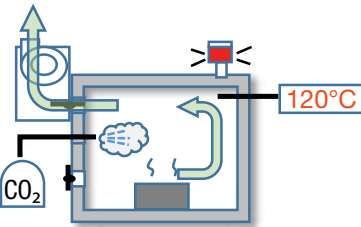

Detect overheating of test area and fire extinguisher is injected.

OPERATION OF SAFETY VENT

300 × 300mm Aluminum foil type

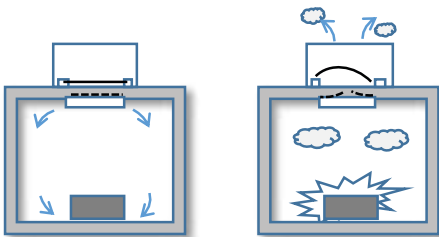

The pressure of the explosion breaks the aluminum foil. It is necessary to exchange a broken aluminum foil with a spare.

Quality is more than a word



ESPEC EUROPE GmbH

Balanstrasse 55 · 81541 Munich · Germany · +49 (0)89 1893 963-0 · info@espec.de · www.espec.de

ESPEC Global Network

